

Hazardous Waste Filtration System User Guide

Millipore Cat. No. YT30 142 HW

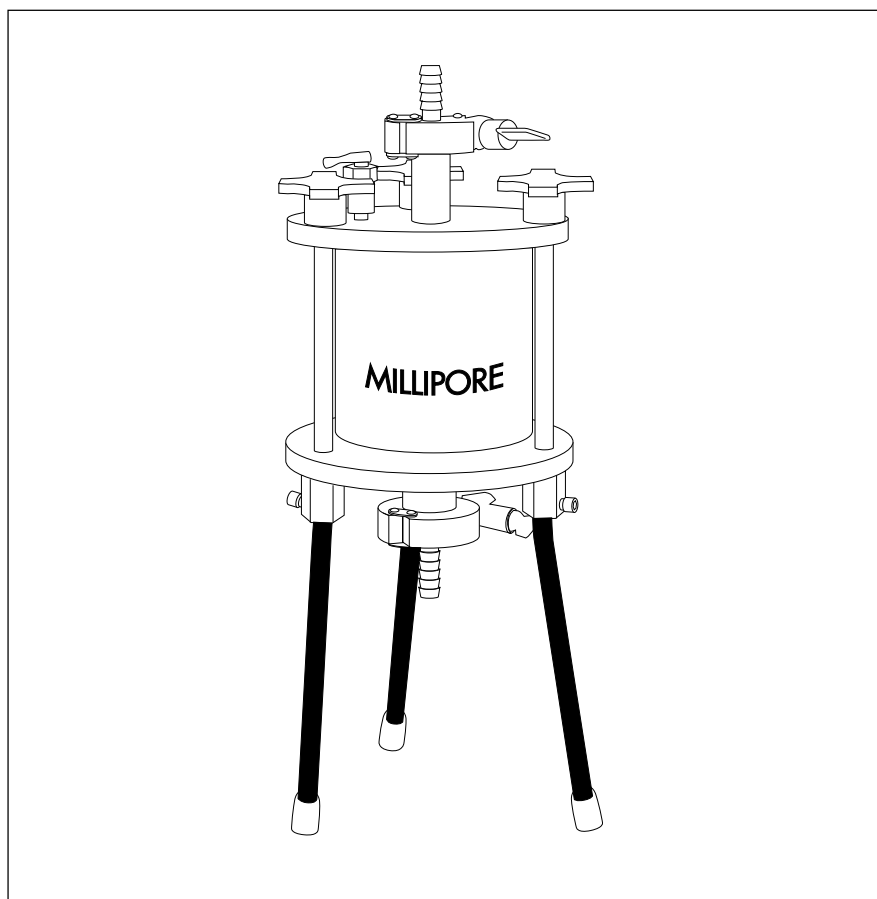

MILLIPORE

Notice

The information in this document is subject to change without notice and should not be construed as a commitment by Millipore Corporation. Millipore Corporation assumes no responsibility for any errors that may appear in this document. This manual is believed to be complete and accurate at the time of publication. In no event shall Millipore Corporation be liable for incidental or consequential damages in connection with or arising from the use of this manual.

© 2003 MILLIPORE CORPORATION. PRINTED IN THE UNITED STATES OF AMERICA. ALL RIGHTS RESERVED. THIS BOOK OR PARTS THEREOF MAY NOT BE REPRODUCED IN ANY FORM WITHOUT THE WRITTEN PERMISSION OF THE PUBLISHERS.

Millipore is a registered trademark of Millipore Corporation.
Teflon is a registered trademark of E.I. du Pont de Nemours and Company.
Tri-Clover is a registered trademark of Alfa Laval Inc.

M11446, Rev. C, 12/03

Contents

Introduction	1
Hazardous Waste Filtration System Diagram and Parts	2
Equipment Assembly	3
How to Use the Hazardous Waste Filtration System	4
Sample Filtration	4
Hazardous Waste Filtration System Specifications	5
Product Ordering Information	6
Technical Assistance	7
Standard Warranty	7

Introduction

The Millipore Hazardous Waste Filtration System (Millipore Cat. No. YT30 142 HW) is used in the toxicity determination of a solid waste in compliance with the U.S. Environmental Protection Agency (EPA) Method 1311 for Toxicity Characteristic Leaching Procedure (TCLP) for semi- and non-volatiles.

NOTE: If you are performing TCLP for volatiles contact Technical Service for information about the Millipore ZHE (Zero Head Space Extractor) Hazardous Waste system.

This system is designed for absolute filtration and separation of solids from liquids by pressure filtration. The 1.5 L extension barrel, top and bottom plates, underdrain support, filter support system, relief valve, and connectors are all constructed of stainless steel. To avoid extraneous contamination from the holder assembly itself, all surfaces of the components (exposed to the test sample) are Teflon[®]-coated. The Tri-Clover[®] (TC) connections of the inlet/outlet of the system allow for ease in removal, cleaning, and maintenance.

Hazardous Waste Filtration System Diagram and Parts

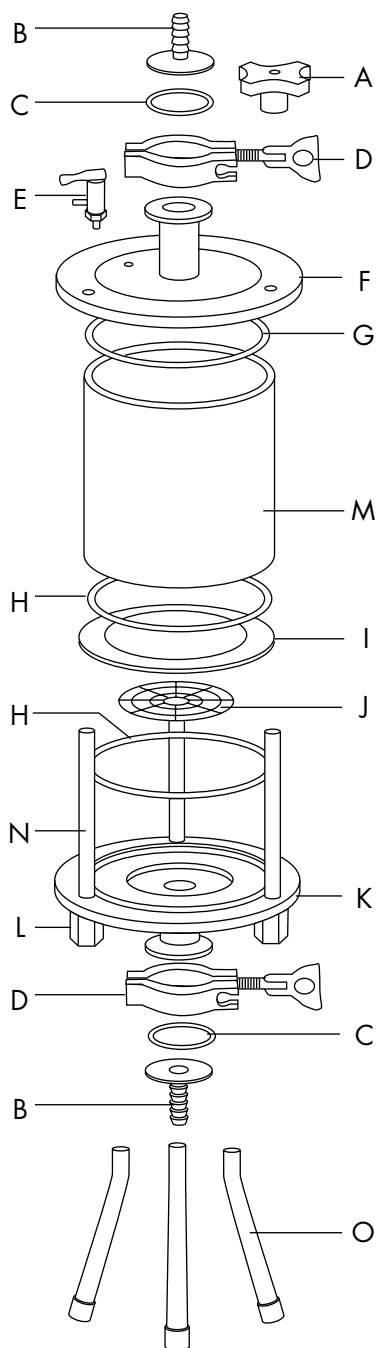

Part	Description	Cat. No.
A	Handwheel Knob	YY22 142 57
B	Tri-Clover (TC) Hose Connector	YY20 040 76
C	TC Silicone Gasket	YY20 040 45
D	TC clamp, 1 1/2"	YY20 040 45
E	Vent Valve	331-1
F	Assembly Top Plate	2195
G	Silicon O-Ring	YY22 142 65
H	Teflon O-Ring	YY22 142 53
I	Screen Support, 142 mm	YT40 142 59
J	Underdrain Support	YT30 142 57
K	Assembly Bottom Plate	2196
L	Leg Bushing/Socket Screw	YY22 142 55
M	Cylinder, 142 mm	
N	Cylinder Extension Post	XX42 090 02
O	Aluminum Legs	YY22 142 51

Equipment Assembly

1. Remove the handwheel knobs from the top of the unit and remove the top plate of the holder assembly. Install Teflon O-ring in the groove at the base of the stainless steel cylinder. Examine underdrain screen to ensure that the radial spokes are down. Then replace support screen.

2. If your method does not include gravimetric analysis proceed to step 3.

If your method includes gravimetric analysis, weigh the filters and prefilters. Or, use the average weight of the AP40 TCLP filter (AP40 142 50) – 1.14g.

3. Place the AP40 Glass Fiber Filter on the base support screen.
4. Center the stainless steel cylinder, grooved end down, onto the filter(s) and obtain an even seal.
5. For procedures requiring a prefilter(s), install the prefilter at this time.

NOTE: Use prefilters with 124 mm diameter.

Lower the prefilter, rough side(s) up, through the cylinder top onto the filter(s). The prefilter may appear oversized; however, it fits snugly against the sides of the cylinder.

6. Place the filter holder's top plate on top of the cylinder rim. The red silicone O-ring fitted into groove of the plate seals it evenly onto the rim. Replace the handwheel knobs on top of unit and screw down evenly until tight. For additional tightening, use the plastic wrench provided.
7. Fit the PVC tubing over the Tri-Clover hose adaptor and secure with a hose clamp. Attach the other end of the PVC tubing to the nitrogen tank regulator outlet and secure it with a hose clamp. Put aside until you are ready to perform the steps in the "Sample Filtration" section.

How to Use the Hazardous Waste Filtration System

TCLP analysis requires a 0.7 µm glass fiber filter without binder (Millipore's AP40 filter).

Other test methods may call for other filter types. Most 142 mm filters can be used with this system. In other applications waste samples can be filtered using only an AP25 glass fiber filter superimposed on an HA (0.45 µm) filter. Some examples include: paper mill effluents, slime muds, secondary sludge, and fly ash. Primary effluents, such as fibers, may require a combination of an AP15 glass fiber filter and a DA (0.65 µm) or AA (0.8 µm) filter in addition to an HA filter to accomplish adequate filtration.

The following section provides a guideline for the filtration of hazardous waste samples for TCLP analysis. See the EPA TCLP Procedure, Method 1311 before starting the procedure.

NOTE: Completing all the procedures in the EPA TCLP Procedure, Method 1311 is necessary to obtain the proper samples for final toxicity analysis. Refer to this method for more information.

Sample Filtration

1. Take a representative sample (minimum size 100 g) of the waste you want to test. Perform the necessary extraction procedure outlined in EPA Method 1311. (Contact Millipore Technical Service for information about using Millipore's Rotary Agitator for extraction.)
2. Pour the extraction fluid into the unit through the Tri-Clover (TC) opening using a funnel. Attach the TC hose adaptor (fitted with 1-½" gasket) to the top plate's TC connection using the stainless steel TC clamp provided.
3. Place an appropriate receiving vessel below the TC sanitary outlet or attach a PVC hose to the TC adaptor and run the hose to an appropriate container.
4. Increase pressure on the nitrogen tank slowly. When the liquid starts to flow from the assembled holder's outlet, immediately turn the regulator valve handle a few turns to lower the pressure. If necessary, bleed air from the top-plate vent valve slowly until pressure gauge reads between 1-10 psi. No leaks should be apparent.

CAUTION: Pressure introduced into the system should not exceed 100psi.

Continue filtration until flow stops.

5. Increase inlet pressure in 10 psi increments to 50 psi, holding for two minutes each time. Continue filtration until flow stops. The liquid should be clear of particulate matter.

NOTE: Keep the liquid fraction under refrigeration at 1–5 °C (34–41 °F) if performing analysis at a later time.

Sample Filtration, continued

6. Shut off the pressure from the nitrogen tank regulator outlet valve, then open the vent valve gradually to release pressure from the cylinder.
7. Remove the inlet TC hose connector and handwheel knobs, and then remove top plate and extension cylinder of holder to clean the unit.

Hazardous Waste Filtration System Specifications

Materials	316 Stainless steel Teflon coated interior surfaces Aluminum legs Molded Polypropylene handwheels Teflon O-rings Silicon O-rings
Dimensions	184 mm (7 1/4") D × 422 mm (16 5/8") H plus inlet connector
Connections	1-1/2" TC Flange with clamps and adaptors for 14 mm (9/16") I.D. hose 1/8" NPTF upstream port for vent/relief
Pressure	7 bar (100 psi) differential 7 bar (100 psi) maximum inlet pressure
Filter diameter	142 mm
Filtration area	120 cm ²
Prefilter Size	Type AP depth filter, 124 mm diameter

Product Ordering Information

This section lists the catalogue numbers for the Hazardous Waste Filtration System, its accessories and filters. See the Technical Assistance section for information about contacting Millipore. You can also buy Millipore products on-line at www.millipore.com/purecommerce.

Description	Catalogue Number
Hazardous Waste Filtration System	YT30 142 HW
Handwheel Knob (3 required)	YY22 142 57
TC Silicon Gasket, 10/pk	YY20 040 55
Tri-Clover Clamp, 1 ½"	YY20 040 45
Vent Valve	331-1
Silicon O-Ring, 4/pk	YY22 142 65
Teflon O-Ring	YY22 142 53
Screen Support, 142mm	YT40 142 59
Underdrain Support	YT30 142 57
Leg Bushing/Socket Screw, 3/pk	YY22 142 55
Cylinder Extension Post, 3/pk	XX42 090 02
Three Legs with Caps and 3/16" Allen Wrench	YY22 142 51
Plastic Handwheel Wrench	YY22 142 52
Accessories	
T.C Gasket, 1 ½" 10/pk	YY20 040 57
PVC Tubing with Clamp, ½" × 10'	XX67 000 35
TCLP Filter	
Glass Fiber Filter, 142 mm, without binder, 50/pk	AP40 142 50
NOTE: Contact Millipore Technical Service for information about appropriate filters for other methods.	

Technical Assistance

For more information, contact the Millipore office nearest you. In the U.S., call **1-800-MILLIPORE** (1-800-645-5476). Outside the U.S., see your Millipore catalogue for the phone number of the office nearest you or go to our web site at www.millipore.com/offices for up-to-date worldwide contact information. You can also visit the tech service page on our web site at www.millipore.com/techservice.

Millipore Corporation is pleased to provide internet access to Material Safety Data Sheets (MSDS) for its products that contain hazardous materials. To obtain any MSDS documents that may be associated with this product, go to the MSDS page of our website at www.millipore.com/msds.nsf/home.

Standard Warranty

Millipore Corporation (“Millipore”) warrants its products will meet their applicable published specifications when used in accordance with their applicable instructions for a period of one year from shipment of the products. **MILLIPORE MAKES NO OTHER WARRANTY, EXPRESSED OR IMPLIED. THERE IS NO WARRANTY OF MERCHANTABILITY OR FITNESS FOR A PARTICULAR PURPOSE.** The warranty provided herein and the data, specifications and descriptions of Millipore products appearing in Millipore's published catalogues and product literature may not be altered except by express written agreement signed by an officer of Millipore. Representations, oral or written, which are inconsistent with this warranty or such publications are not authorized and if given, should not be relied upon.

In the event of a breach of the foregoing warranty, Millipore's sole obligation shall be to repair or replace, at its option, the applicable product or part thereof, provided the customer notifies Millipore promptly of any such breach. If after exercising reasonable efforts, Millipore is unable to repair or replace the product or part, then Millipore shall refund to the customer all monies paid for such applicable product or part. **MILLIPORE SHALL NOT BE LIABLE FOR CONSEQUENTIAL, INCIDENTAL, SPECIAL OR ANY OTHER INDIRECT DAMAGES RESULTING FROM ECONOMIC LOSS OR PROPERTY DAMAGE SUSTAINED BY ANY CUSTOMER FROM THE USE OF ITS PRODUCTS.**

MILLIPORE